

HANDPUNCH[®] 2000

TIME & ATTENDANCE TERMINAL



Put your hands on the accurate, affordable solution.

- ▶ *Saves money over card-based systems*
- ▶ *Provides the most accurate time and attendance solution available*
- ▶ *Fast and easy to use*
- ▶ *Eliminates badges*
- ▶ *Eliminates buddy punching*

Acroprint Time Recorder, Inc. now brings the accuracy and convenience of biometric technology easily within reach of most time and attendance applications. In operations that range from coal mines to clean rooms, RSI systems have proven themselves to be a practical and precise solution. Our terminals are so affordable, it doesn't make sense to consider any other technology.

Smarter than card-based terminals

There are no cards to create, administer, carry -- or lose. The HandPunch verifies employees' identities in less than one second, based on the unique size and shape of their hands.

HandPunch clearly notifies each user of a match using red and green indicator lights. Because no one can punch

in or out for your employees, the system reduces time theft and improves payroll accuracy.

Versatile and Programmable

Beyond a simple time clock, the HandPunch 2000 provides definable data management keys that allow data collection when employees punch. The systems transmit data to the time and attendance host PC through a variety of options, depending on the model. Model differences let you tailor the right system for your company's size and needs.

When you want to cut time and attendance costs...do it by hand.



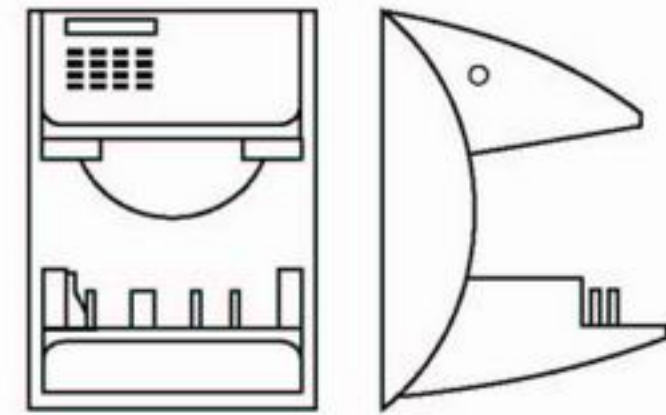

Hand Geometry Technology

The HandPunch 2000 uses RSI's field-proven hand geometry biometric technology. The terminal captures a three-dimensional image of the hand each time the employee punches. The hand's size and the shape are used to verify their identity with unparalleled accuracy. No fingerprints or palm prints are utilized. Green and red lights notify the employee of the status of each punch. There's no question any more; employees have to be there to punch.

Programmable Data Management Keys

The HandPunch 2000 has two user-definable data management keys that let you collect data as employees punch. Common uses include department transfers, tips collected, job codes, or pay codes. Multi-level data entry sequences may be defined. You can also set the data management keys to allow employees to review their past punches. To reduce keystrokes, the keys can also be set to automatically enter data such as a frequently used department number or in/out status.

SPECIFICATIONS

Size	8.85 in. (22.3 cm.) wide 11.65 in. (29.6 cm.) high 8.55 in. (21.7 cm.) deep
Weight	6 lbs. (2.7 kg)
Power	12-24 VDC or 12-24 VAC 50/60 Hz
Verification time	Less than 1 second
Memory Retention	Up to 5 years via the standard internal lithium battery
Transaction Buffer	5187 transactions.
ID Number Length	1 to 10 digits
Baud Rate	300 – 28.8K bps

HANDPUNCH 2000

Part Number	HP-2000
Communications	RS-232, 100 foot cable included
User Capacity	512 Users
Options	
BB-200	Operational Battery Backup
MD-500	High Speed Internal Modem

HANDPUNCH 2000

Communication Options

The HandPunch 2000 connects quickly to the time and attendance PC via a provided 100-foot RS-232 communications cable. An optional dial-up high speed modem is available for remote sites.

Note: Some time and attendance software packages may not have implemented all of these features in their system software. Please check with your system vendor for details.

Specifications subject to change
HandPunch® is a registered trademark of Recognition Systems, Inc.